

MEISER[®]

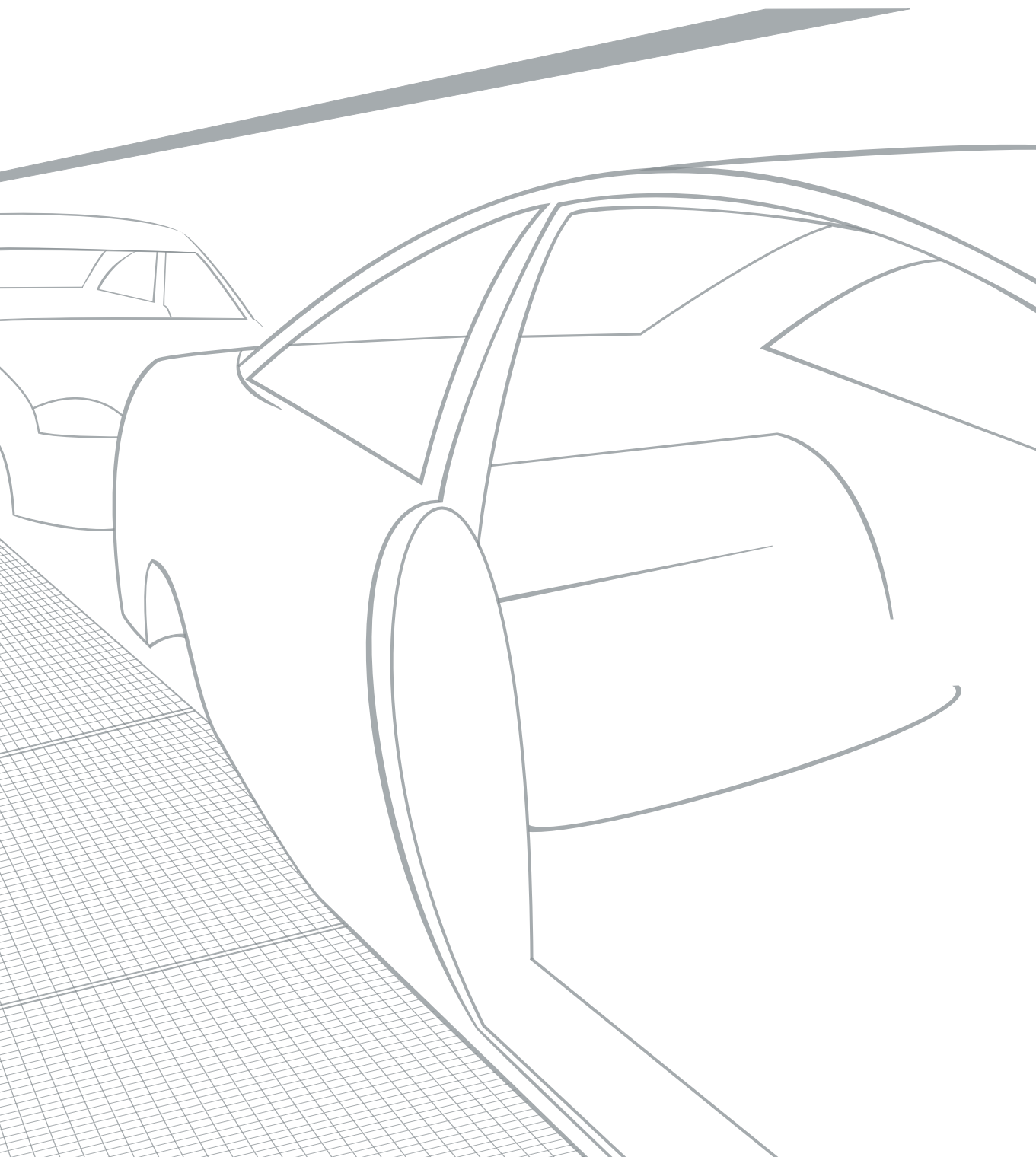

Automotive

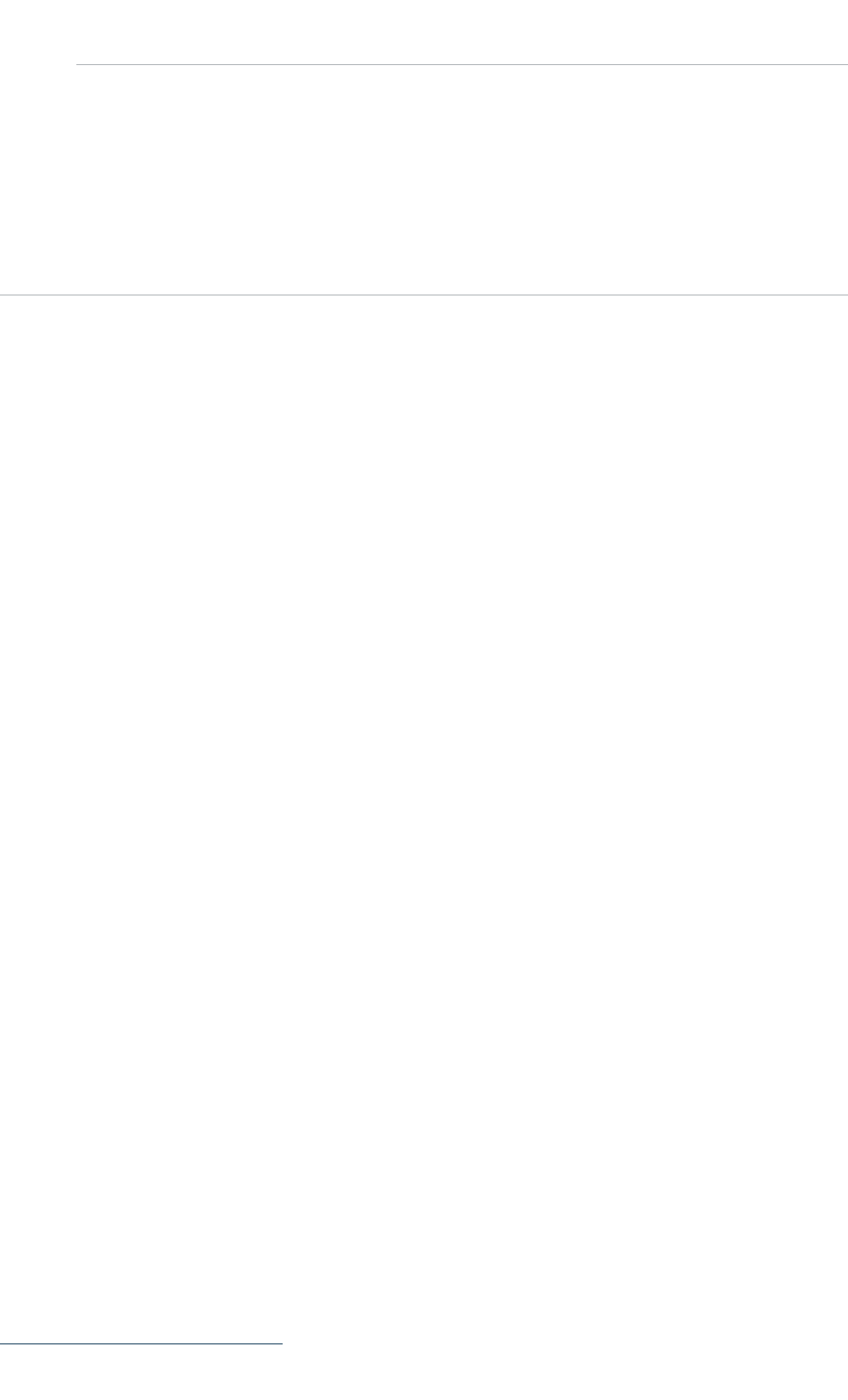



Contents	3
Introduction	6
Sheet metal profile grating, open	8
Sheet metal profile grating, closed	12
Installation of Stepbloc F / Drainstep RH-3	14
Fall protection panels	18
Fixing & connecting panels for fall panels	22
Grating	24
Fixing Clips for grating	26
Slip resistance	27
Car parks	28
Floor plates	30
Industrial handrail systems	31
Service	32
Contact partners	33
Imprint	35

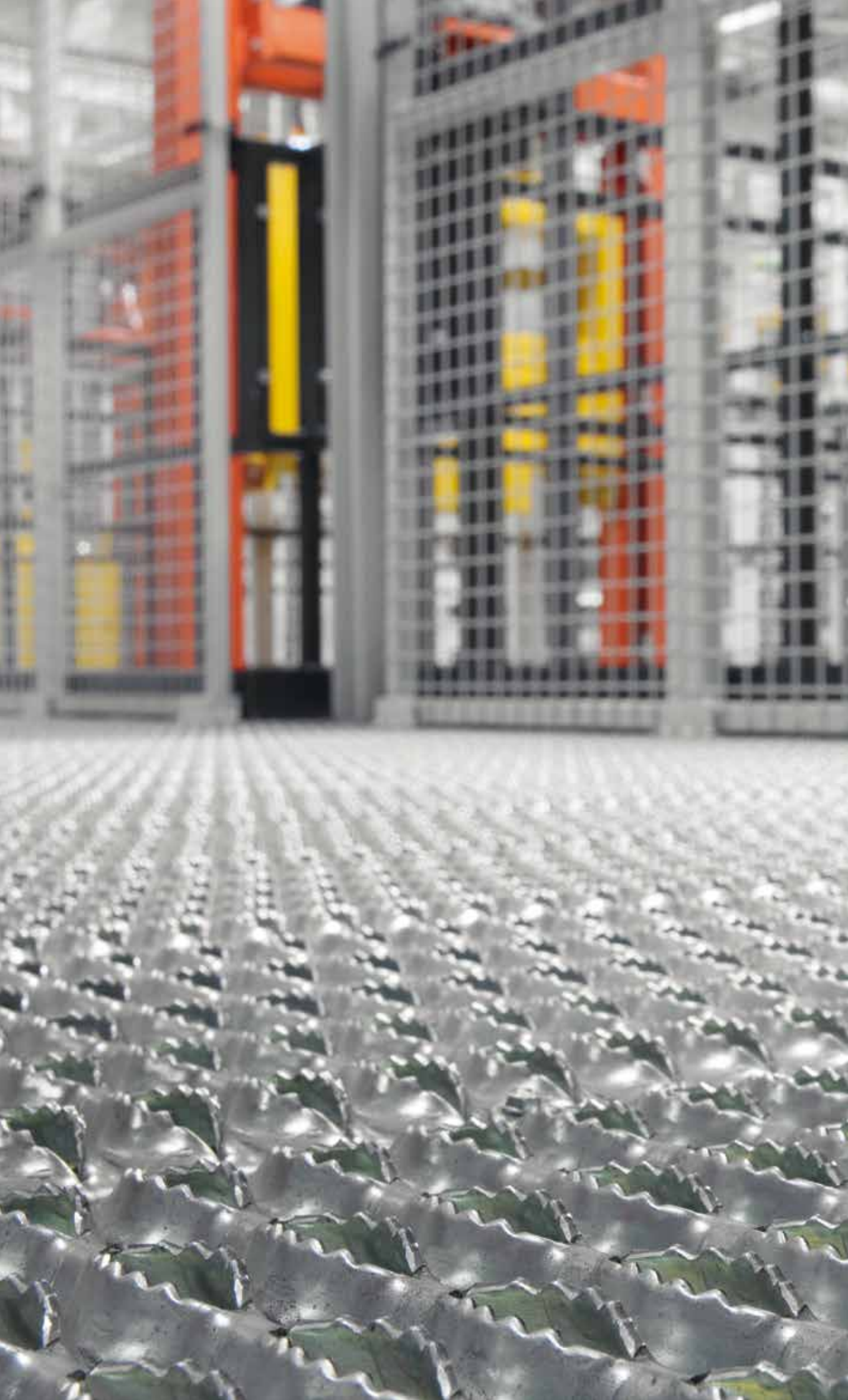



Introduction

MEISER - Supplier of platform flooring and staircase systems to the automotive industry

For many years MEISER has been the sole supplier to the Automotive Industry, offering a complete range of platform flooring.

We have taken on board various design requirements of the automotive industry, and correspondingly expanded our supply range to meet the requirements of this.

Our supply range:

- Sheet metal profile grating, open
- Sheet metal profile grating, closed
- Sheet metal profile grating, sprinkler-compatible corresponding to FM Global guidelines
- Fall protection panels corresponding to the current automotive industry standards
- Grating
- Chequer plates
- Industrial system handrails
- Installation technology

Our service:

- On-site consulting and support from planners, architects and project managers
- Technical office with experience in major global projects
- Very large production capacities at various locations
- Branch offices worldwide and supervision of work on site
- Further development of the product range thanks to in-house development department
- Continuous compliance with the latest standards in cooperation with customers and inspection institutions





MEISER sheet metal profile „Stepbloc F“

MEISER Stepbloc F has for many years had an established place as platform flooring in the automotive industry. The toothing of the very prominent surface gives the grating excellent stability, and in addition guarantees a high degree of slip resistance, particularly in areas where the work involves grease and oil.

Your advantages

- Easy and quick to install
- Slip resistance category up to R 13
- High stability thanks to C-bending
- Highly effective drainage



Material	Sheet thickness	Slip resistance analysis
Steel - self colour/ hot-dip galvanised (DD11)	2,0 / 2,5 / 3,0	R13 / R12
Steel Sendzimir galvanised (DX51Z275)	2,0 / 2,5 / 3,0	R13 / R12
Aluminium (AlMg ³)	2,5 / 3,0	R13 / R12
Stainless steel (1.4301)	2,0	R13 / R12
Widths [mm]	124 / 182 / 298 / 356 / 414 / 475	
Heights [mm]	30 / 50 / 75 / 100	
Lengths [mm]	Length increments of 30 mm, max. 6000 mm	

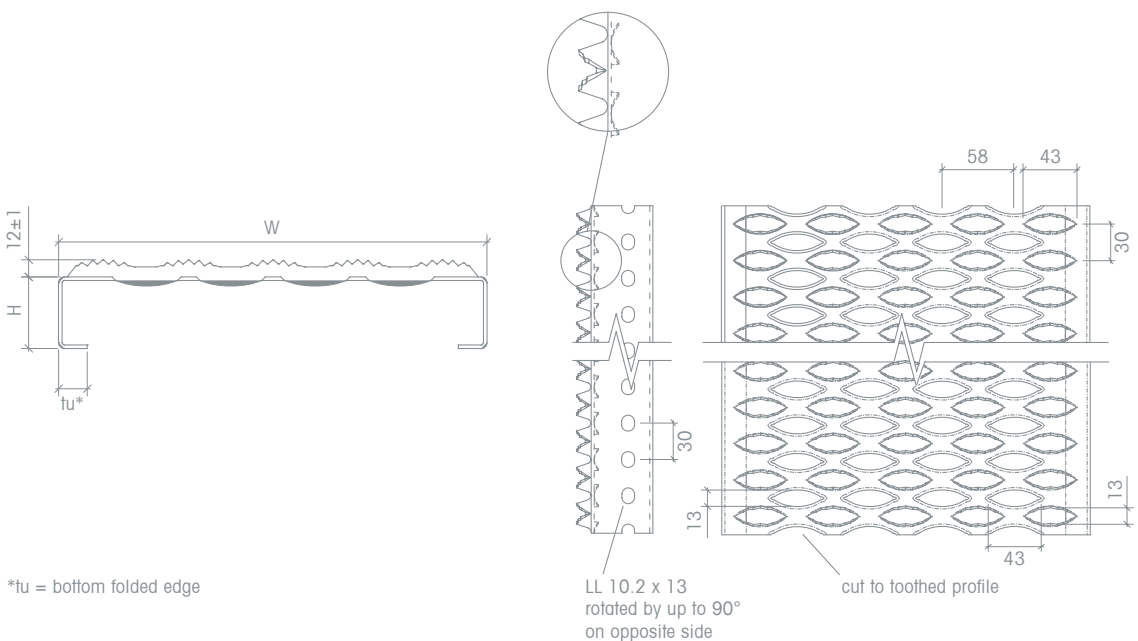



DRAINSTEP RH-3

The MEISER sheet metal profile grating DRAINSTEP RH-3 is a grating that was newly developed in 2012. Its characteristics make it unique in the MEISER sheet metal profile product range. Over 70% open cross-section ensures it has maximum drainage effect. DRAINSTEP RH-3 was developed on the basis of EN ISO 14122-2, and ensures compliance with the higher requirements for dropped ball protection (20 mm ball). Installed on inclined catwalks ensures excellent transverse rigidity with this sheet metal profile grating.

Possible applications

- Catwalks / platforms / surfaces in areas with high volumes of snow / precipitation (e.g. roof access grating)
- Areas where work is performed with oil / grease, or areas with increased risk of dirt (e.g. agriculture, industry)
- Surfaces where a high drainage effect is required (e.g. intermediate platforms or conveying levels under sprinkler systems)



Material	Sheet thickness	Slip resistance analysis
Steel - self colour / hot-dip galvanised (DD11)	2,0 / 2,5	R10
Steel Sendzimir galvanised (DX51)	2,0 / 2,5	R10
Widths [mm]	200 / 300 / 312 / 324, other widths than these result in a reduction in the open cross-section	
Heights [mm]	40 - 150 mm, special heights upon request	
Lengths [mm]	Increments of 42.5 mm with a max. 6,250 mm	

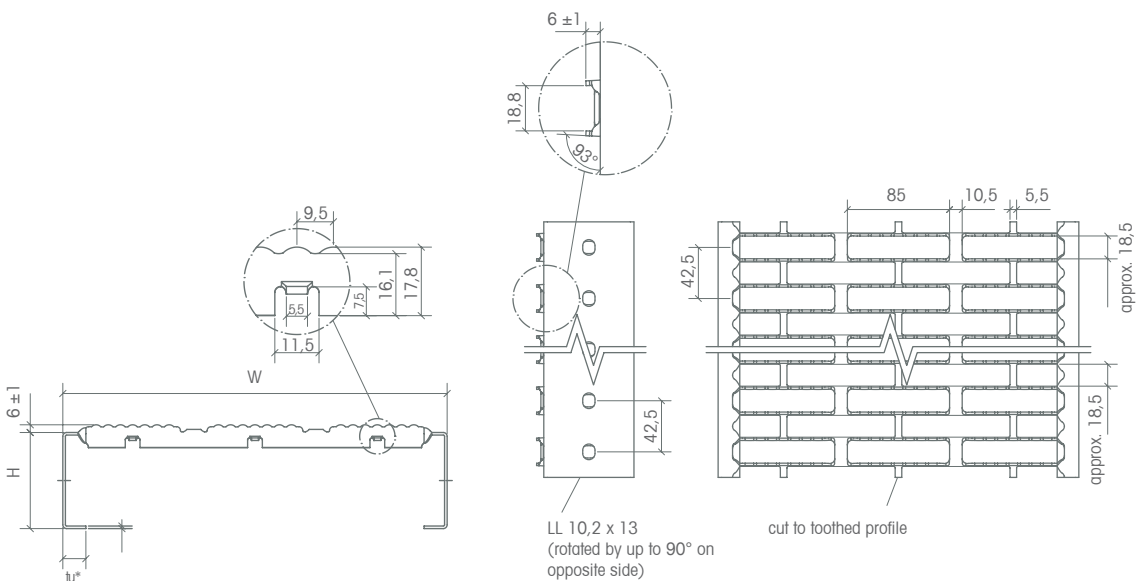

*tu= bottom folded edge

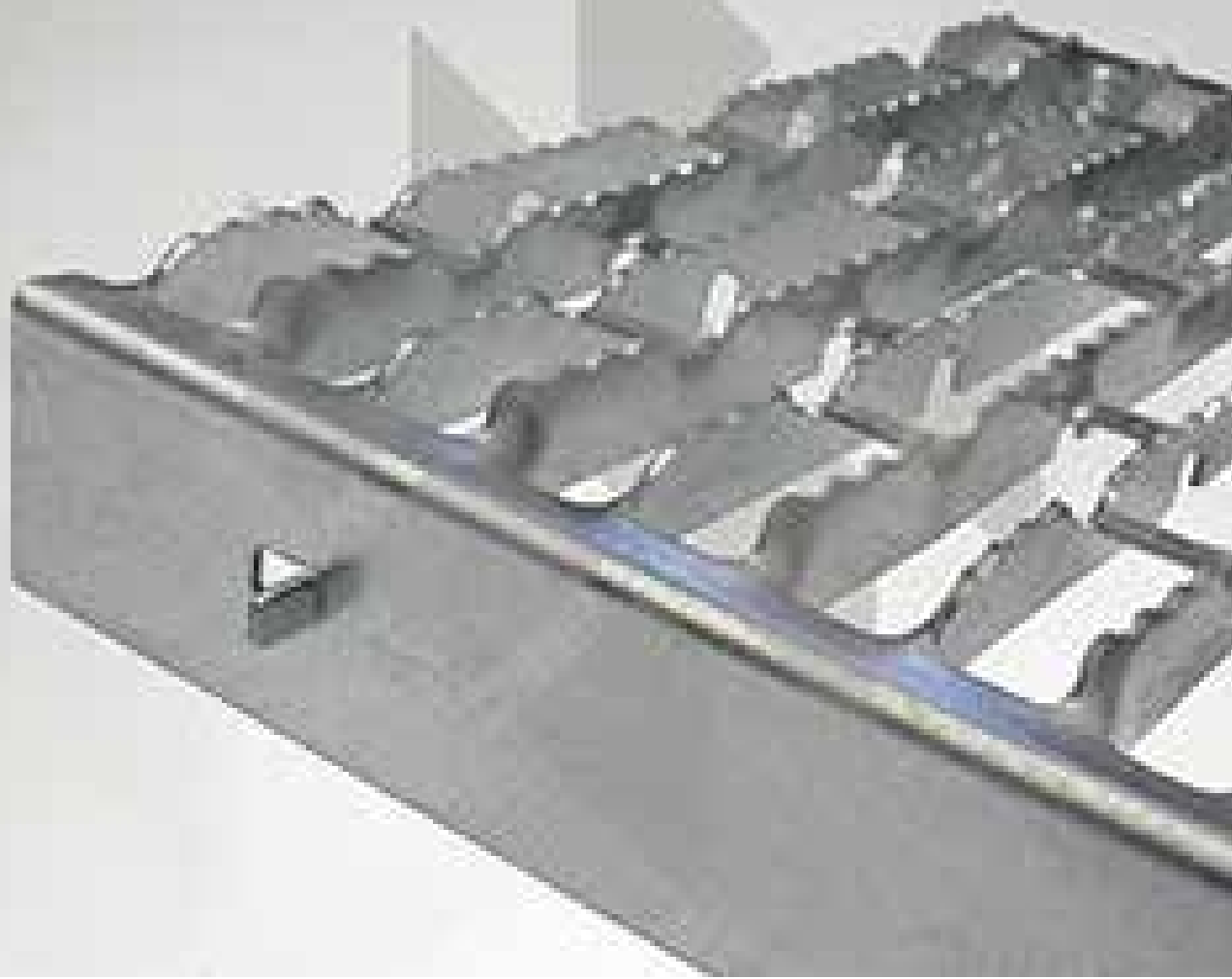

MEISER sheet metal profile „Steplarm G“ hot-dip galvanised

The surface structure is comparable to a chequer plate, making this product an attractive alternative, but with a greater load-bearing capacity at higher span widths. Steplarm is a closed grating that has proven itself very well in public areas with pedestrian traffic, and in commercial use, e.g. in the construction of production facilities.

Your advantages

- Suitable for platform and foundation flooring
- Edged as a „C-profile“
- Closed, patterned surface
- Comparable to the structural form of chequer plate
- Open ends
- Long-side with lateral holes for bolting the profiles together
- Slip resistance category R10



Material	Sheet thickness	Slip resistance analysis
Steel - self colour / hot-dip galvanised (DD11)	2,0 / 2,5	R 10
Steel Sendzimir galvanised (DX51Z275)	2,0 / 2,5	R 10
Aluminium (AlMg ³)	2,5 / 3,0	R 10
Stainless steel (1.4301)	-	-
Widths [mm]	120 / 180 / 240 / 300 / 360 / 420 / 480	
Heights [mm]	30 / 40 / 50 / 75 / 100	
Lengths [mm]	Length increments of 30 mm, max. 6000 mm	

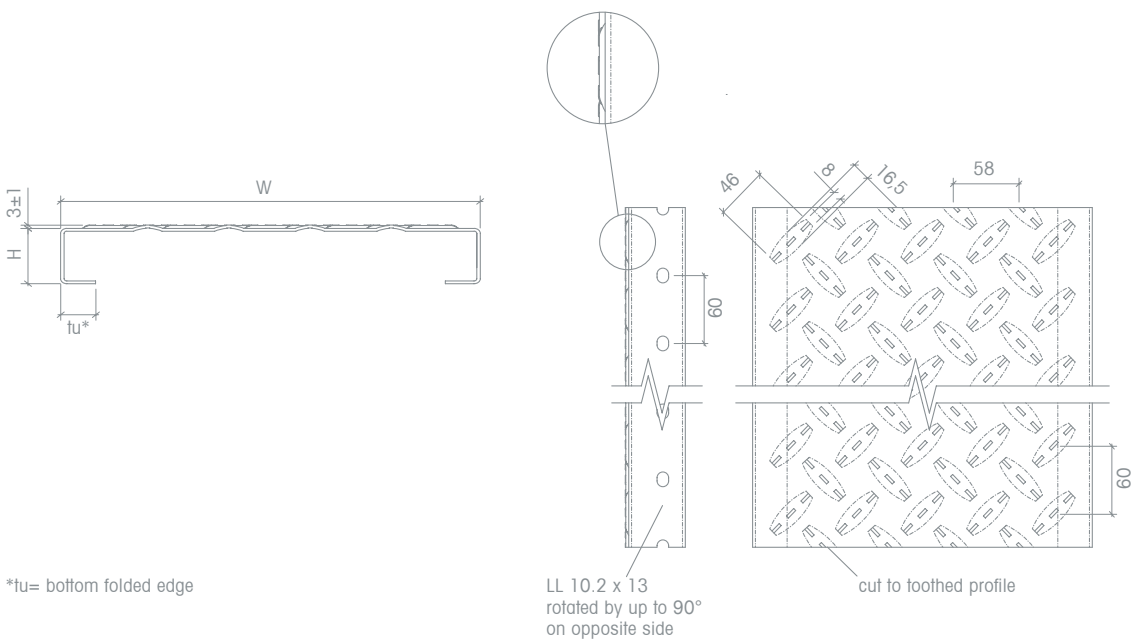



Installation of Stepbloc F / DRAINSTEP RH-3 in combination with fixing bolts and lateral projection lugs

The lateral projecting steel lugs of the planks slot into the opposite depressions in the adjacent profile grating. When one plank is loaded, this ensures that no trip hazard results from the edge of the adjacent plank. When fixing bolts are used (see drawing), there is no need for further joining of the planks e.g. with connecting bolts or connecting plates.

Your advantages

- Lower mounting costs
- Installation completely free drilling debris etc., therefore no additional cleaning work required
- This system can save approx. 50% of the installation costs compared to the systems of other suppliers
- Assembly from above is possible

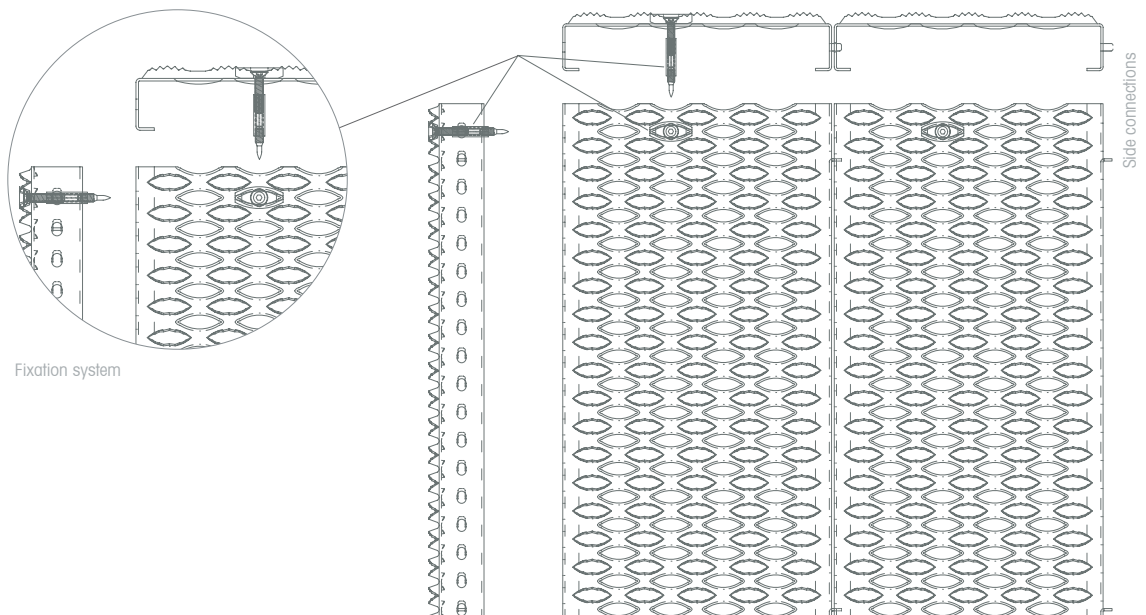
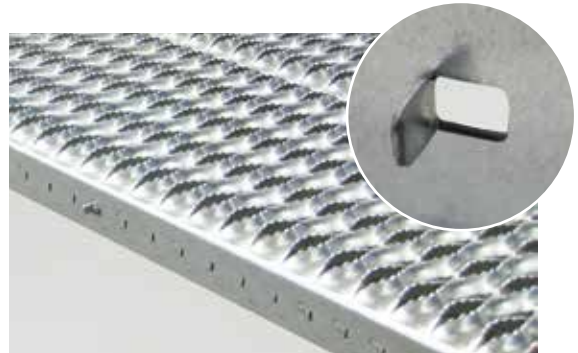

INSTALLATION AND FASTENING SCHEME



Industrie Service

The verification of the serviceability of the fixing principle combining fixing bolts and side projection lugs has been tested by TÜV Süd Germany, and can be made available upon request.



Fixing bolts

Olive with fixation system and projecting side lugs

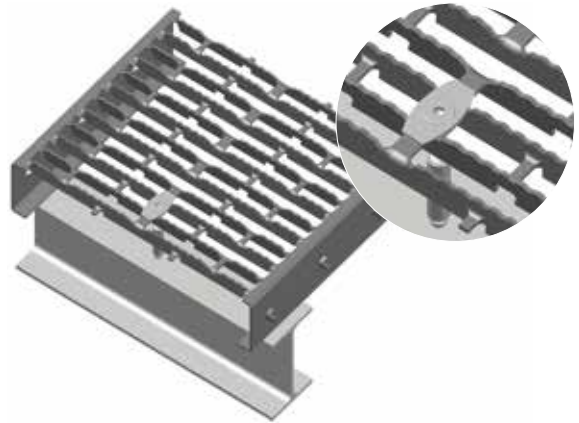

Bolted side connections

Consisting of special bolts with washers and self-locking nuts to connect the grating planks to one another



Connecting plate

Fixing for connecting the grating planks to one another laterally; Installation from above, including drilling screws



Olive with drilling screw

Cast upper section for all Stepbloc shapes with fixation bolt system; Utility patent protected by MEISER

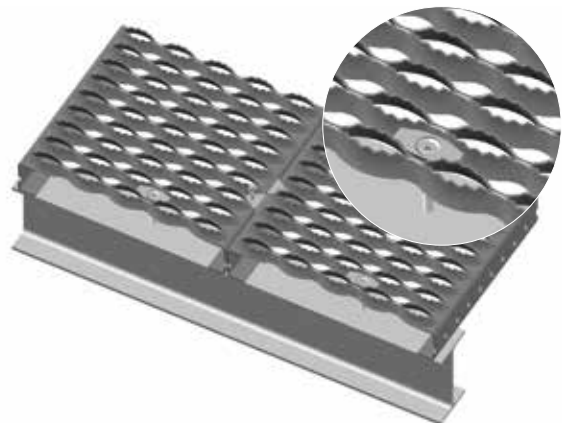



Fall protection panels

MEISER fall protection panels are the ideal solution for covering large areas such as false ceilings, defining the edges of stages and enclosing conveyor systems.

They consist of a load bearing tubular frame and welded-on mesh grid. The tubular frame type and the size of the mesh grid are usually defined in the factory standards of the individual automobile manufacturers.

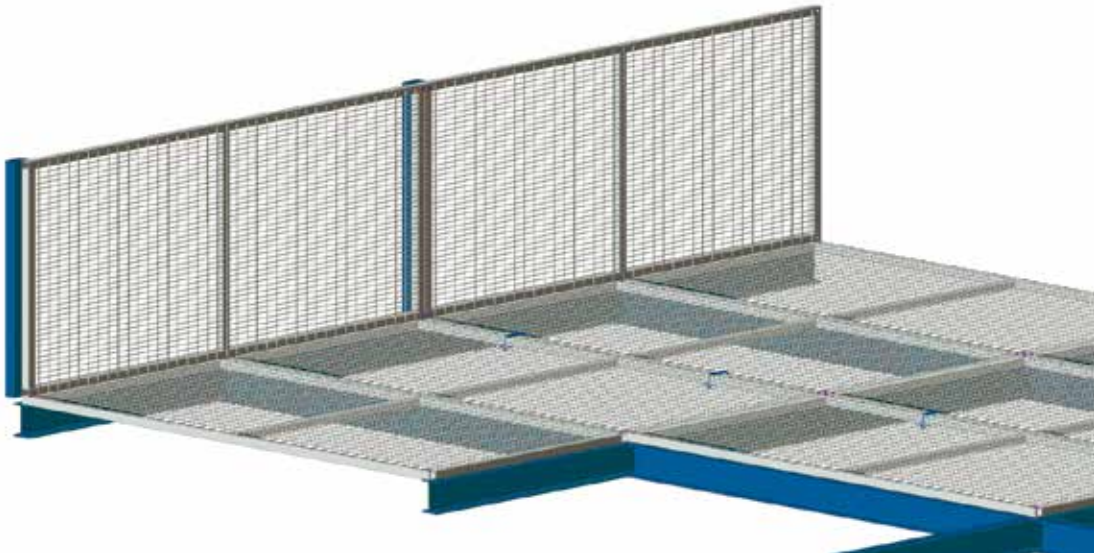

A distinction is made with respect to the fall protection panels between floor elements & side protection.

In the case of a floor panel, the mesh grid is chosen in such a way that objects are prevented from falling through. Over the last few years, one particular solution has become established here which prevents a test ball with a diameter of 20 mm from falling through, corresponding to DIN EN ISO 14122-2.

For side protection panels, this 20 mm ball protection is also available, although other specifications may demand larger mesh widths.

MEISER fall protection panels are usually delivered with a single powder-coated surface. This surface treatment is advantageous from the ecological perspective and fully adequate with respect to the requirements of corrosion protection. Upon request, a hot-dip galvanised surface corresponding to DIN EN ISO 1461 is of course also available. The MEISER fall protection panels are attached in accordance with the respective factory standards by means of U-clamps or directly using drilling screws or fixing bolt technology.

Your advantages

- Installation planning & delivery of fall protection panels, sheet metal profiles & grating from a single supplier
- Delivery of standard & special panels in uniformly high quality
- Fast installation thanks to relatively large panel sizes
- Tested fixing systems



MEISER fall protection panels - BMW® type

BMW® FLOOR PANEL 1

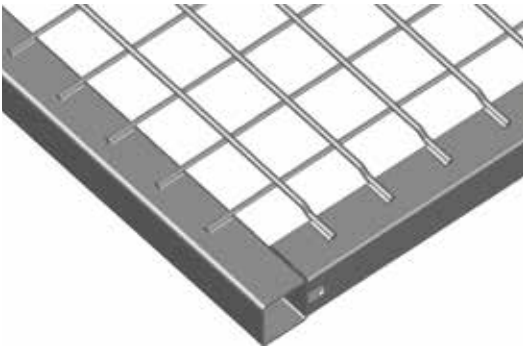

Tubular frame	Mesh grid
40 x 40 x 2,5 mm	50 x 50 mm; 5 x 5 mm
Surfaces	
Powder-coated RAL 9006	

BMW® FLOOR PANEL 2

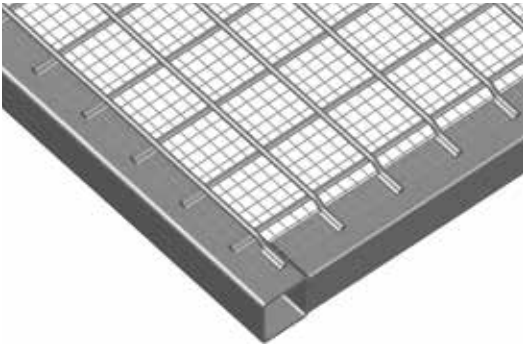

Tubular frame	Mesh grid
40 x 40 x 2,5 mm	50 x 50 mm; 5 x 5 mm with fine grating 10 x 10 mm
Surfaces	
Powder-coated RAL 9006	

BMW® FLOOR PANEL 3

Tubular frame	Mesh grid
40 x 40 x 2,5 mm	50 x 50 mm; 5 x 5 mm
Surfaces	
Powder-coated RAL 9006	

MEISER fall protection panels

FLOOR PANEL & SIDE PROTECTION PANELS

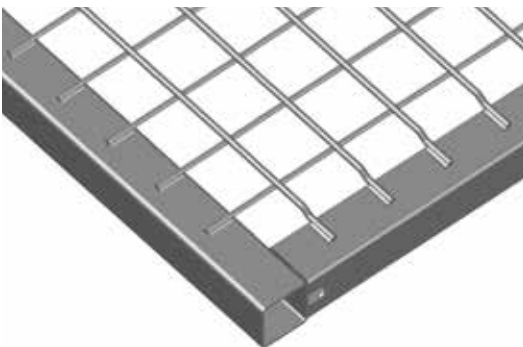

Tubular frame	Mesh grid
40 x 40 x 3 mm	50 x 50 mm; 5 x 5 mm
Surfaces	
Hot-dip galvanised corresponding to DIN EN ISO 1461	

MEISER fall protection panels- Audi-VW® type

AUDI-VW® FLOOR PANEL

Tubular frame	Mesh grid
35 x 35 x 2,5 mm	23 x 50 mm; 3,8 x 5 mm
Surfaces	
Powder-coated RAL 9002	



AUDI-VW® SIDE PROTECTION PANELS

Tubular frame	Mesh grid
35 x 35 x 2,5 mm	23 x 50 mm; 3,8 x 5 mm
	40 x 40 mm; 5 x 5 mm
Surfaces	
Powder-coated RAL 9002	

MEISER fall protection panels - Daimler® type

DAIMLER® FLOOR PANEL & SIDE PROTECTION PANELS

Tubular frame	Mesh grid
35 x 35 x 2,5 mm	23 x 50 mm; 3,8 x 5 mm
Surfaces	
Powder-coated RAL 9002	



In addition to the respective standard panel sizes manufactured, MEISER also manufactures special sizes resulting from the installation planning. Alternative colours to the factory standard can also be supplied on the basis of RAL colour charts.



U-clamps

The conventional connection of floor panels to one another, as well as floor panels for side protection, is carried out using the U-clamp. It consists of a U-shaped clamp, adapted to the support dimensions, a counter-plate and two locking nuts. U-clamps are supplied in galvanised form.



With a correspondingly adapted U-clamps, it is also possible to clamp floor panels and side protection panels to beams and columns.

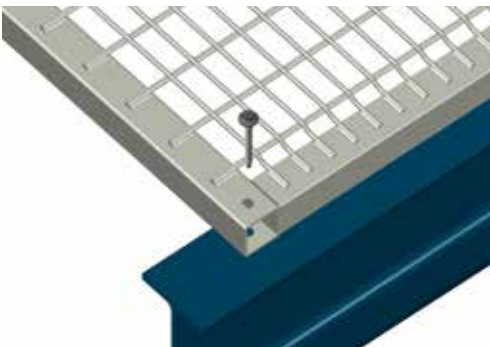

Direct attachment with drilling screws

By means of drilling screws, it is possible to speed up the installation. MEISER provides the necessary drill-holes in the tubular frame of the fall protection panels in the factory during production.

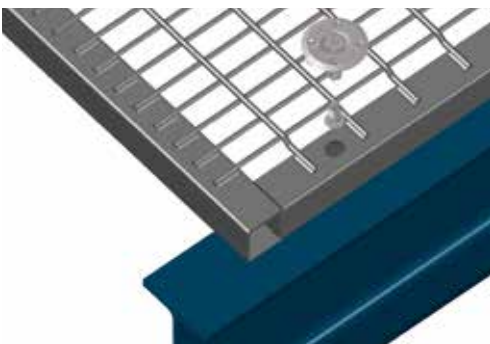

Direct attachment with fixing bolt technology

Another simplified installation method is fixing bolt technology. Here too, the required drill-holes are incorporated into the tubular frame by MEISER in the factory during production.

Bolting onto support rail HM50/30

If support rails are used on the steel substructure, this screw connection can be made with a slot nut, bolt and mat clamp.

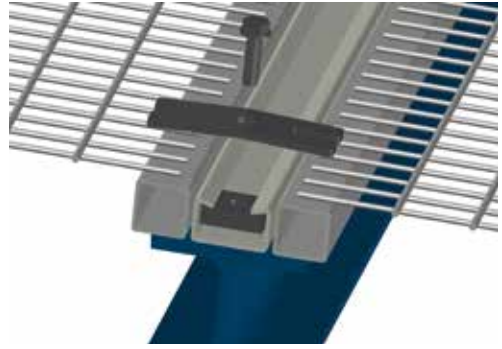

Panel joints with connecting plate

Unsupported joints of fall protection panels may have to be supported in order to transmit loads & deflections. A connecting plate can be used for this. This is adapted to the height of the tubular frame and is easy to assemble.

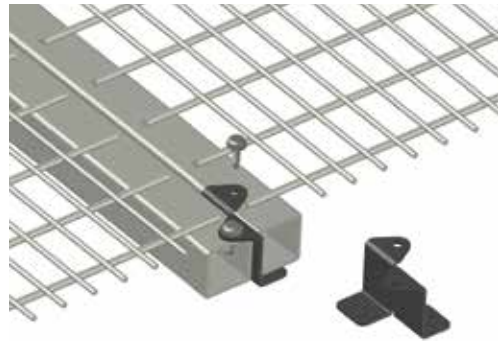

Panel joints with welded-on clamping plates

Alternatively, alternating clamping plates can be welded on to the longitudinal sides of the fall protection panels. These also provide reliable support to the panel joint.

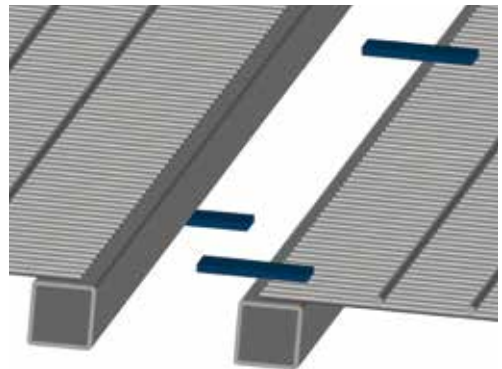

The MEISER grating

Thanks to its flexibility, grating is frequently used in various areas throughout the automotive industry. The mesh spacing, load-bearing capacity and slip resistance properties of MEISER grating can be adapted to defined installation locations and application purposes in a very targeted manner. This process can use either press-welded grating or press-locked grating, both of which have their own specific advantages.



Press-locked grating is frequently used in outdoor applications or other areas where there is a particularly high requirement for the slip-resistant properties of the floor covering. The grating can be manufactured with a slip resistance class of R10 to R13 and because many different mesh spacings can be manufactured, drop-through protection for various small parts can be guaranteed whilst ensuring compatibility with fire sprinkler systems for levels located below.

Standard bearing bar profiles

Common mesh spacings for bearing bars from 2 to 3 mm

Bearing bar	Cross bar								
11,1	11,1	16,65	-	22,2	33,3	44,4	49,95	66,6	99,9
15	11,1	16,65	-	22,2	33,3	44,4	49,95	66,6	99,9
21	11,1	16,65	21,0	22,2	33,3	44,4	49,95	66,6	99,9
22,2	11,1	16,65	21,0	22,2	33,3	44,4	49,95	66,6	99,9
33,3	11,1	16,65	21,0	22,2	33,3	44,4	49,95	66,6	99,9
44,4	11,1	16,65	21,0	22,2	33,3	44,4	49,95	66,6	99,9
55,5	11,1	16,65	21,0	22,2	33,3	44,4	49,95	66,6	99,9
66,6	11,1	16,65	21,0	22,2	33,3	44,4	49,95	66,6	99,9
99,9	11,1	16,65	21,0	22,2	33,3	44,4	49,95	66,6	99,9

Common mesh spacings for bearing bars from 2 to 3 mm

Bearing bar	Cross bar							
21	16,65	22,2	33,3	44,4	50	66,6	99,9	
25	16,65	22,2	33,3	44,4	50	66,6	99,9	
33,3	16,65	22,2	33,3	44,4	50	66,6	99,9	
50	16,65	22,2	33,3	44,4	50	66,6	99,9	
66,6	16,65	22,2	33,3	44,4	50	66,6	99,9	
99,9	16,65	22,2	33,3	44,4	50	66,6	99,9	

Bearing bar

2 mm	3 mm	4 mm	5 mm
20/2	20/3	-	-
25/2	25/3	25/4	25/5
30/2	30/3	30/4	30/5
35/2	35/3	35/4	35/5
40/2	40/3	40/4	40/5
45/2	45/3	45/4	45/5
50/2	50/3	50/4	50/5
-	60/3	60/4	60/5
-	70/3	70/4	70/5
-	80/3	80/4	80/5
-	90/3	90/4	90/5
-	100/3	100/4	100/5
-	-	-	110/5
-	-	-	120/5
-	-	-	130/5
-	-	-	140/5
-	-	-	150/5
-	-	-	160/5
-	-	-	170/5

We will of course be pleased to fulfil any special wishes that you may have!

The MEISER press-welded grating

Press-welded grating is characterised by the high stability of the respective grating. In this process, all intersection points are welded together, thus giving the grating a high degree of torsional rigidity, even when overloaded. Press-welded grating can also be manufactured with a slip resistance class of R10 to R12, and is frequently used in conveyor levels, painting lines and production plants. Tried-and-tested mesh widths ensure that dropped ball protection is guaranteed for various small objects, e.g. 20 mm balls.

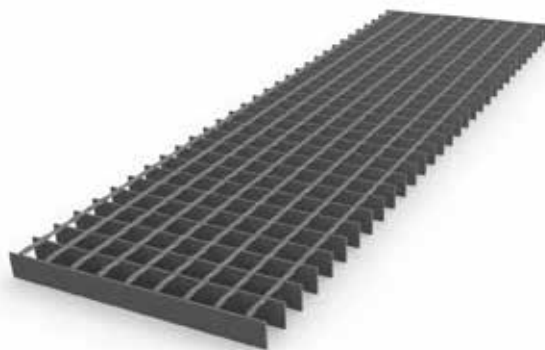

Common mesh spacings

Bearing bar	Cross bar						
15,08	-	-	-	38,1	50,8	76,2	101,6
17,15	-	-	-	38,1	50,8	76,2	101,6
20,77	-	24,0	-	38,1	50,8	76,2	101,6*
23,69	-	24,0	-	38,1	50,8	76,2	101,6*
25,00	-	-	-	-	-	76,2	101,6
30,15	-	-	-	38,1	50,8	76,2	101,6
33,00	-	-	31,75	-	-	-	-
34,30	19,25	24,0	-	38,1	50,8	76,2	101,6
41,45	-	24,0	-	38,1	50,8	76,2	101,6
45,23	-	24,0	-	38,1	50,8	76,2	101,6
51,45	-	24,0	-	38,1	50,8	76,2	101,6
60,30	-	24,0	-	38,1	50,8	76,2	101,6

*possible with restrictions

Standard bearing bar profiles

Bearing bar	2 mm			3 mm			4 mm			5 mm		
-	20/3	20/4	20/5									
25/2	25/3	25/4	25/5									
30/2	30/3	30/4	30/5									
35/2	35/3	35/4	35/5									
40/2	40/3	40/4	40/5									
45/2	45/3	45/4	45/5									
-	50/3	50/4	50/5									
-	60/3	60/4	60/5									
-	70/3	70/4	70/5									
-	80/3	80/4	80/5									

Plated Grating - Grating with plain or chequer plate welded on top

This product provides a greater load bearing capacity when compared individually to grating or plated floors. The high load-bearing capacity and weight to strength ratio of plated grating provides a cost efficient solution to a closed floor requirement. The grating is optimised in mesh and bearing bar thickness for the application areas specified and then welded to the Plain or Chequer plate before finish coating is applied. The customer thus has the advantage of a closed floor product with a homogeneous surface finish and a simple fixing system. This product is frequently used under transformer cabinets or in vehicular areas.

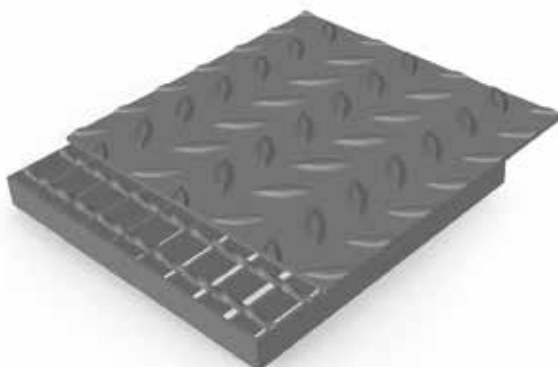

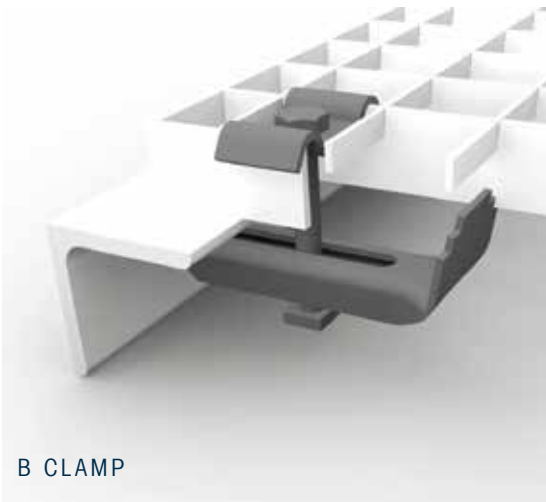

B CLAMP

B clamp

Consists of upper clamp section, lower clamp section, hexagon bolt M8 x 60 and square nut M8.

Galvanised

Designation	Mesh width [mm]
M0531	33 x 33
M0531	34 x 38
M2231	33 x 21

V2A

Mesh width [mm]
33 x 33
34 x 38
33 x 21

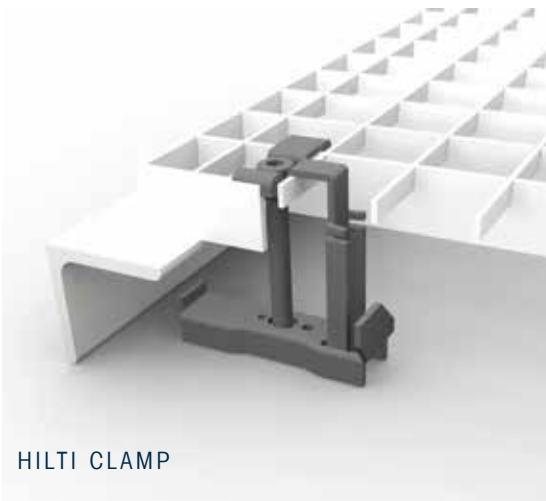

HILTI CLAMP

Hilti clamp XMGR

Consists of upper and lower clamp sections connected to one another; high resistance to vibrations, easy assembly by one person and thereby significantly shorter installation times.

Galvanised

Designation	Mesh width [mm]
XMGR	33 x 33 / 34 x 38 / 34 x 24

maximum grating height 40 mm

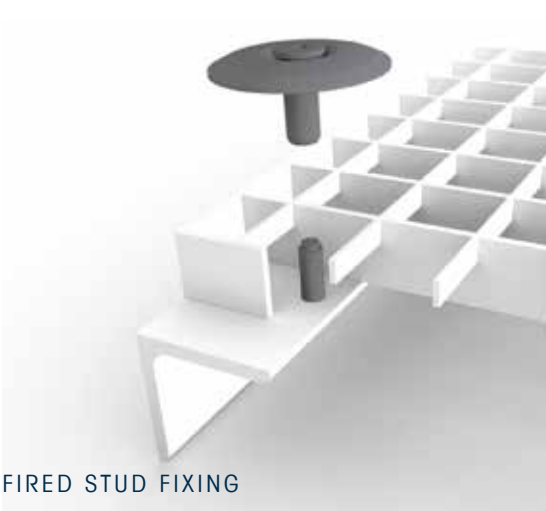

FIRED STUD FIXING

Fired stud fixing

Consists of fired stud and top clip disc, for highly corrosive environments (e.g. offshore), also available as X-BT, pre-assembled version X-GR RU.

Galvanised

Designation	Mesh width [mm]
X-FCM + X-M8	22 x 22 – 66 x 66
X-FCM + X-BT	22 x 22 – 66 x 66
X-GR-RU	33 x 33

V4A

Mesh width [mm]
22 x 22 – 44 x 44
22 x 22 – 44 x 44

Slip resistance

In recent years the issue of the slip resistance of walkable surfaces has gained in importance. Wherever work is carried out with glide-enhancing substances, i.e. where oils, greases and emulsions are used, there is an increased risk of slipping.

Outdoors, the weather plays a crucial role. Rain and snow quickly transform many areas into slides. MEISER offers a solution to this problem and provides a safe grip with MEISER anti-skid grating. These greatly reduce the risk of slipping. Depending on the regulations or personal safety needs, MEISER can supply grating with a classification from R9 to R13.

The required R number for different fields of application is specified by the „Professional Association Rule for Safety and Health at Work (BGR181)“.

An analysis of this slip resistance capability is carried out by an independent test institution with clearly defined test equipment (see illustration).

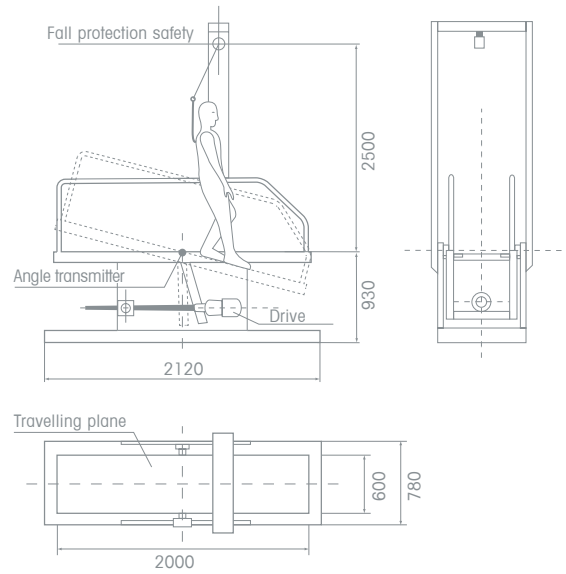

Classification

Degree	R Class
from 3° to 10°	R9
from 10° to 19°	R10
from 19° to 27°	R11
from 27° to 35°	R12
more than 35°	R13



Special grating as facades on car parks or process buildings

Grating is also being used ever more frequently as facades. The special properties of press-locked grating or louvre grating form the decisive application criteria here. Grating can be used on facades to protect against birds, provide glare protection for vehicle headlights, as a visual barrier for prototypes, or as a design element with individual colouring.

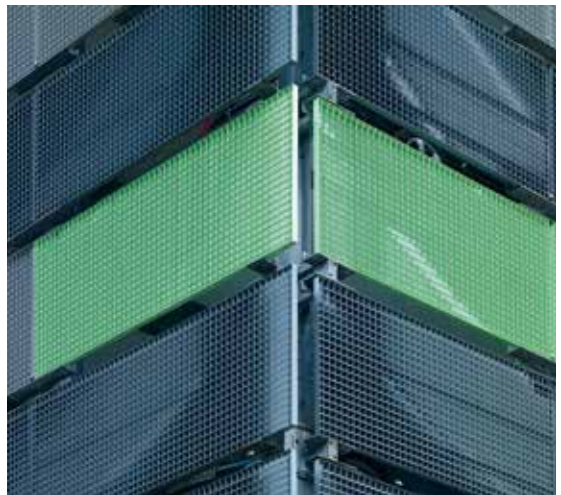

With our many years of experience, we offer the right solution options for your individual requirements and desires!

RIGHT:
AUDI CAR PARK, INGOLSTADT



S46

Truppenhaus

Ausfahrt



MEISER chequer / plain floor plates

MEISER is primarily known as a leading manufacturer of grating. Our product range also includes industrial floor coverings to which new variants are continuously being added.

Standing still is a foreign concept for us. Discover our new "plate" products, and you will be convinced by the advantages.

Your advantages

- Individual manufacturing to order
- We can prepare the installation drawings upon request
- Marking and positioning according to your specifications
- All necessary preparations for fixings are made at the factory, e.g. countersunk fixing holes
- We stock plates of various dimensions thus guaranteeing short delivery times
- For us, quality assurance is a matter of course
- Closed surface
- Simple installation and assembly
- Good travel surface for hand pallet truck or small trolleys

Material	Common thicknesses
Steel - self colour / hot-dip galvanised (DD11)	3/5, 5/7, 6/8, 8/10, 10/12
Aluminium (AlMg ³)	Further dimensions upon request
Stainless steel (1.4301)	



MEISER industrial handrail systems

The MEISER industrial handrail system builds on a simple modular design. Vertical handrail standard posts and horizontal handrails are combined with one another to form a flexible system.

The vertical handrail standard posts are metal tubes having one or more balls which are drilled to accommodate the handrails and come complete with welded on base plates which are drilled for fixing to the support structure.

Thanks to the modular design of the system, the application areas are virtually unlimited and extend from the industrial sector, through use in factory halls, to steel platforms and in harbours, all the way up to modern architecture and space design.

Your advantages

- Quick installation
- Corrosion-resistant and long-lasting
- Individual manufacturing to order
- Cost-effective alternative to conventional handrail systems

Handrail standard design					Recommended distance at 1100 mm standard height		
Type		Post	Ball	Hole	220 N/m	360 N/m	740 N/m
Pipe	TL	Ø 33,7 mm	65 mm	36 mm	1500 mm	950 mm	470 mm
	TM	Ø 42,4 mm	82 mm	45 mm	1900 mm	1500 mm	750 mm
	TH	Ø 48,3 mm	94 mm	50 mm	200 mm	1800 mm	970 mm
Full material	SL	Ø 32 mm	60 mm	36 mm	1650 mm	1150 mm	570 mm
	SH	Ø 40 mm	70 mm	45 mm	2000 mm	1800 mm	1090 mm



Service

For MEISER, service means providing its clients not only with high-quality products, cost-effectively and on schedule, but also with the greatest possible degree of additional benefits.

This begins with our offering you an extensive planning service. As professionals in the field of profile grating, we are able to plan an application faster and better than a planner who only deals with this topic from time to time or even for the first time.

A further special attraction for us is solving unusual tasks. We do not want to reduce your ideas to the possibilities at our disposal, but rather expand our possibilities through the development of new solutions. That is why new tasks are not only a technical challenge to us, but also the opportunity to improve and develop as a company.

Put us to the test!

Planning / Manufacturing / Assembling

Our offer to you includes the planning, manufacture and upon request, assembly and compilation of installation plans - all under one roof.

The continuous development of new products and the refinement of existing ones for a wide range of applications enable us to satisfy your requirements.

Service is our top priority. For you this means:

- Advice on design, standards and regulations
- Preparation of assembly and manufacturing drawings
- Development of customer-specific special solutions

For us, quality assurance is a matter of course. The designs comply - where necessary - with the latest DIN / EN standards, the conditions of the German accident prevention regulations and of the Professional Associations.



Contact partners

In order to really focus on your wishes and requirements, MEISER relies on an old-fashioned but tried and tested sales strategy: personal customer care.

Put your faith in short communication channels and reliable contact persons who advise you on the basis of their experience and expertise, highlight possible solutions and will immediately provide you with assistance in the event that not everything is running smoothly. In our opinion this is the only correct way to ensure that your requirements are met.

We will not abandon this course, because it is the way to achieve quality and reliability which begins with the products and certainly does not end with customer support.

Our team is happy to help.

Gebr. MEISER GmbH
Edmund Meiser Straße 1
D-66839 Schmelz-Limbach

Tel +49 (0) 68 87 - 309 0
Fax +49 (0) 68 87 - 309 3000

Email info@meiser.de

MEISER Vogtland OHG
Am Lehnteich 3
D-08606 Oelsnitz

Tel +49 (0) 37 421 - 50 0
Fax +49 (0) 37 421 - 50 2120

Email info@meiser.de

All contact partners can be found on our homepage at www.meiser.de!



Imprint

Design, concept, technical illustration and
lithography: MEISER

Photography: Tom Gundelwein, MEISER

Subject to technical development without notice.

We exclude all liability for any errors or omissions.

500 / 01.2017

